

THIS DRAWING IS UNPUBLISHED. RELEASED FOR PUBLICATION
 © COPYRIGHT 20 BY - ALL RIGHTS RESERVED.

LOC		DIST		REVISIONS			
P	LTR	DESCRIPTION	DATE	DWN	APVD		
CM	00	F	REVISED PER ECO-15-005484	28JUL2015	SC	DZ	

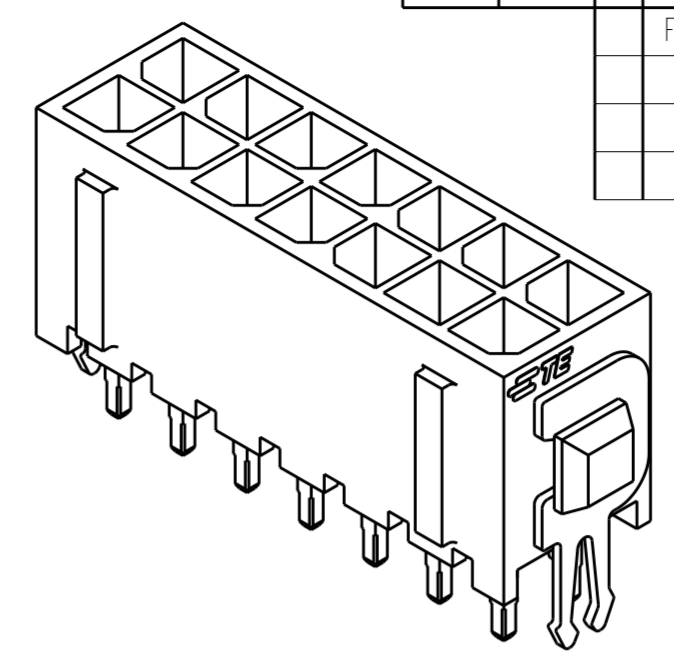

3 DIMENSIONAL MODEL

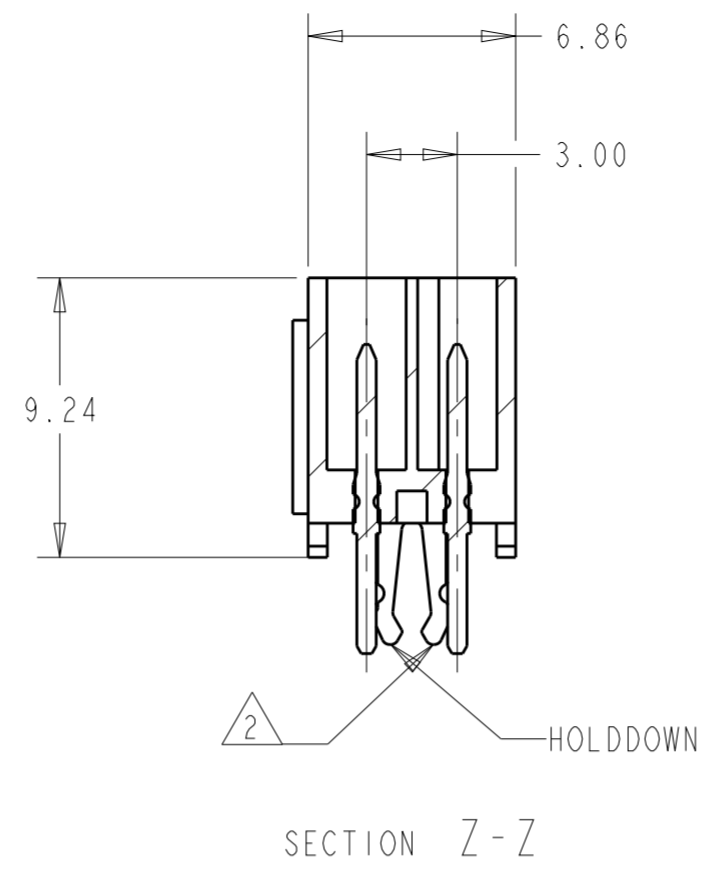
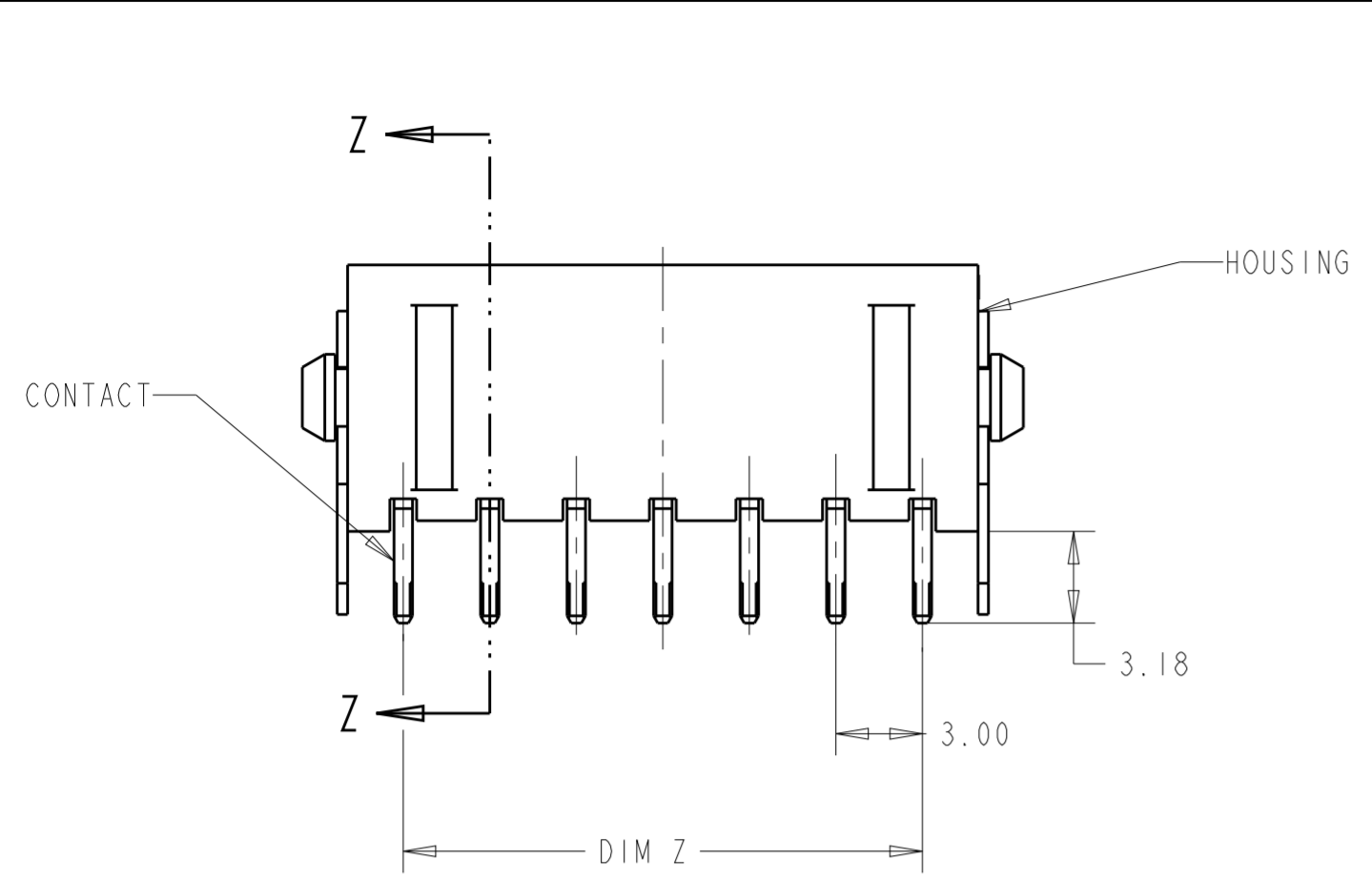
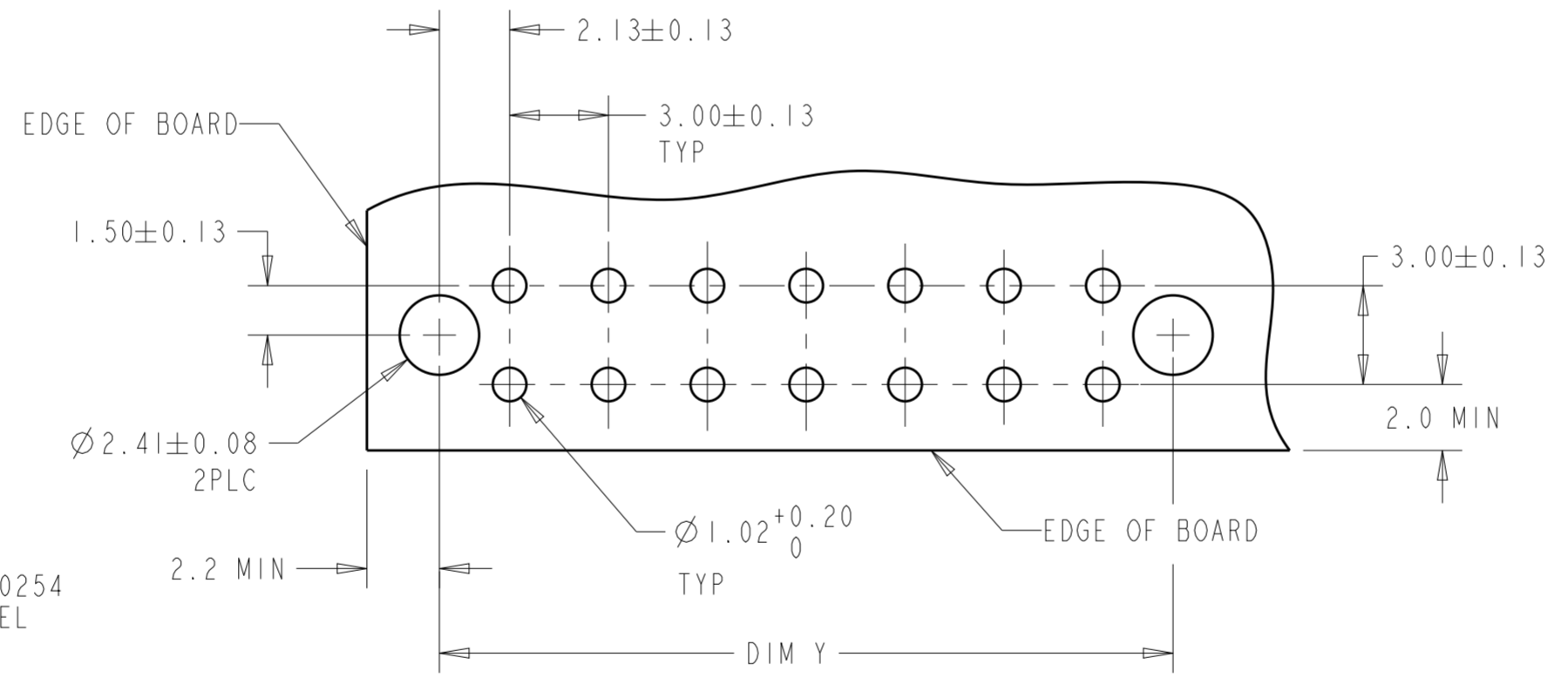
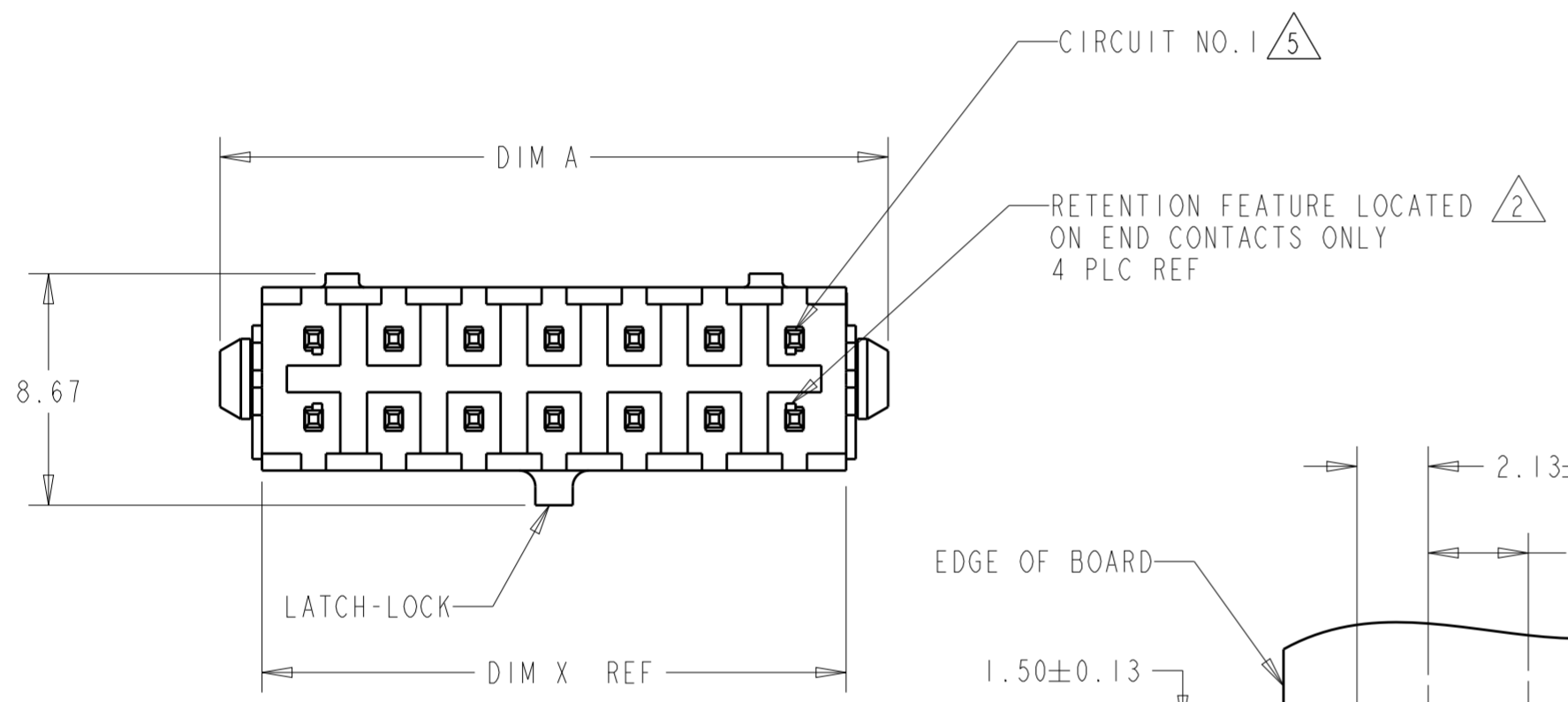

RECOMMENDED MOUNTING HOLE PATTERN SCALE 5:1

1 MATERIAL: HOUSING - NYLON, UL 94V-0, BLACK.
 CONTACT - BRASS.
 0.000762 MINIMUM GOLD OVER 0.00254
 MINIMUM NICKEL ON MATING AREA. 0.00254
 TIN-LEAD MINIMUM OVER 0.00254 NICKEL
 MINIMUM ON SOLDER TAILS.
 HOLDDOWNS: PHOSPHOR BRONZE, .00254 TIN-LEAD.

2 MAXIMUM INSERTION 30 LBS.

3 RECOMMENDED BOARD THICKNESS 1.57.

4 MATERIAL: HOUSING - NYLON, UL 94V-0, BLACK.
 CONTACT - BRASS.
 0.000762 MINIMUM GOLD OVER 0.00254
 MINIMUM NICKEL ON MATING AREA. 0.00254
 MATTE TIN MINIMUM OVER 0.00254 NICKEL
 MINIMUM ON SOLDER TAILS.
 HOLDDOWNS: PHOSPHOR BRONZE, .00254 MATTE TIN.

5 CIRCUIT NUMBER 1 IS LOCATED AT THE BOTTOM RIGHT
 WITH THE LATCH-LOCK ON TOP LOOKING INTO THE CAVITIES

FINISH	DIM A	DIM Z	DIM Y	DIM X	NO. OF POSN.	PART NUMBER
4	40.00	33.00	37.30	36.86	24	5-794682-4
4	37.00	30.00	34.30	33.86	22	5-794682-2
4	34.00	27.00	31.30	30.86	20	5-794682-0
4	31.00	24.00	28.30	27.86	18	4-794682-8
4	28.00	21.00	25.30	24.86	16	4-794682-6
4	25.00	18.00	22.30	21.86	14	4-794682-4
4	22.00	15.00	19.30	18.86	12	4-794682-2
4	19.00	12.00	16.30	15.86	10	4-794682-0
4	16.00	9.00	13.30	12.86	8	3-794682-8
4	13.00	6.00	10.30	9.86	6	3-794682-6
4	10.00	3.00	7.30	6.86	4	3-794682-4
4	7.00	-	4.30	3.86	2	3-794682-2
1	40.00	33.00	37.30	36.86	24	2-794682-4
1	37.00	30.00	34.30	33.86	22	2-794682-2
1	34.00	27.00	31.30	30.86	20	2-794682-0
1	31.00	24.00	28.30	27.86	18	1-794682-8
1	28.00	21.00	25.30	24.86	16	1-794682-6
1	25.00	18.00	22.30	21.86	14	1-794682-4
1	22.00	15.00	19.30	18.86	12	1-794682-2
1	19.00	12.00	16.30	15.86	10	1-794682-0
1	16.00	9.00	13.30	12.86	8	794682-8
1	13.00	6.00	10.30	9.86	6	794682-6
1	10.00	3.00	7.30	6.86	4	794682-4
1	7.00	-	4.30	3.86	2	794682-2

THIS DRAWING IS A CONTROLLED DOCUMENT.

DIMENSIONS: mm [INCHES]	TOLERANCES UNLESS OTHERWISE SPECIFIED: 0 PLC ± 1 PLC ± 2 PLC ±0.20(.008) 3 PLC ± 4 PLC ± ANGLES ± FINISH	DWN B. HAYMAKER 16AUG99 CHK K. COBLE 16AUG99 APVD K. COBLE 16AUG99	TE Connectivity	
MATERIAL SEE TABLE	SEE TABLE	PRODUCT SPEC APPLICATION SPEC WEIGHT	NAME VERTICAL HEADER ASSEMBLY, THRU HOLE, 30 GOLD, DUAL ROW, MICRO MATE-N-LOK™	
CUSTOMER DRAWING		SIZE A2	CAGE CODE 00779	DRAWING NO. C-794682
SCALE 4:1		SHEET 1 OF 1 REV F		